

MCC-MCE

Corrosion-free Closed Circuit Cooling Towers

Corrosion-free Evaporative Condensers

MCC-MCE
Series



Closed circuit evaporative cooling towers Series MCC and evaporative

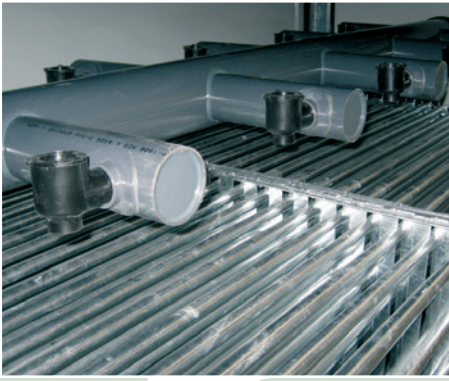

■ MCC Series: closed circuit evaporative cooling towers

The MCC series closed circuit evaporative cooling towers are employed as an alternative to open-type cooling circuits with heat exchangers, in those cases in which the cooling fluid for the user's equipment (generally water or water with glycol) must maintain its chemical and physical characteristics constant over time and unpolluted by external elements. In fact the fluid to be cooled circulates within the tubes constituting the heat exchanger coil placed inside the cooling tower: the coil, in turn, is continuously wetted by the water contained in the basin of the tower, which is sent to a spray system with nozzles via the appropriate pump.

Thanks to the combined effects of the evaporation of a small part of the spray water and of the turbulence created inside the tubes, the cooling of the fluid, which can hence be returned to the user's equipment, is achieved.



■ MCE Series: evaporative condensers

The MCE series evaporative condensers can be employed in air conditioning and industrial refrigeration installations, representing in their operation an alternative to the classical water-cooled condenser with evaporative cooling tower or systems with aircooled finned coils.

The refrigerant gas to be condensed is fed to the upper header of a coil of smooth-surface tubes which, continuously wetted by water appropriately sprayed and in contact with an adequate countercurrent airflow, permits the progressive condensation of the gas. The gas, thus cooled and condensed to the liquid state, can be returned via the lower header to the installation.

Hence the evaporative condenser, in the context of water-cooled condensing systems combines the "open circuit cooling tower condenser" system in a single and compact unit exploiting, inside the unit, the forced evaporation of a small quantity of the recirculating spray water to achieve the heat load rejection which is necessary to condensate the refrigerant gas.



■ Constructional features

Fitted with one or more axial fans according to the model, the MCC and MCE series are built with a strong supporting structure in hot-dip galvanised steel and side walls made of fibreglass sandwich panels. The internal heat exchanger is composed of smooth-tube coils, fabricated in compliance with PED directive 97/23/EC for MCE series only. The standard configuration is completed by the water collecting basin and the fan stacks made entirely of fibreglass (FRP).

The range includes several models suitable for installations with requested refrigeration capacities between approx. 80 and 1700 kW.

For all models several option items are available, such as:

- Different solutions to reduce sound emissions
- Totally removable side walls for an easy and total access to the internal parts, to simplify inspection, cleaning or maintenance operations.



■ Fields of application

The closed circuit cooling tower is employed in industrial plants and civil air conditioning installations, in particular:

- cooling of delicate equipment such as air compressors, moulds and plastic extrusion machines, pipe-manufacturing (using an emulsion of anti-corrosion additive in the water of the closed circuit) or induction furnaces (with demineralised water)
- evaporative chilling (cooling tower's direct production of cold water for an air conditioning installation when the chiller is shutdown in the low season) and load shaving (direct production of cold water upstream of a chiller thus only subject to partload).

The evaporative condenser serving refrigeration plants can be employed in the following sectors:

- civil and industrial air conditioning installations
- industrial logistics
- refrigerated warehouses (e.g. storage of food products)
- industrial refrigeration





Structural characteristics

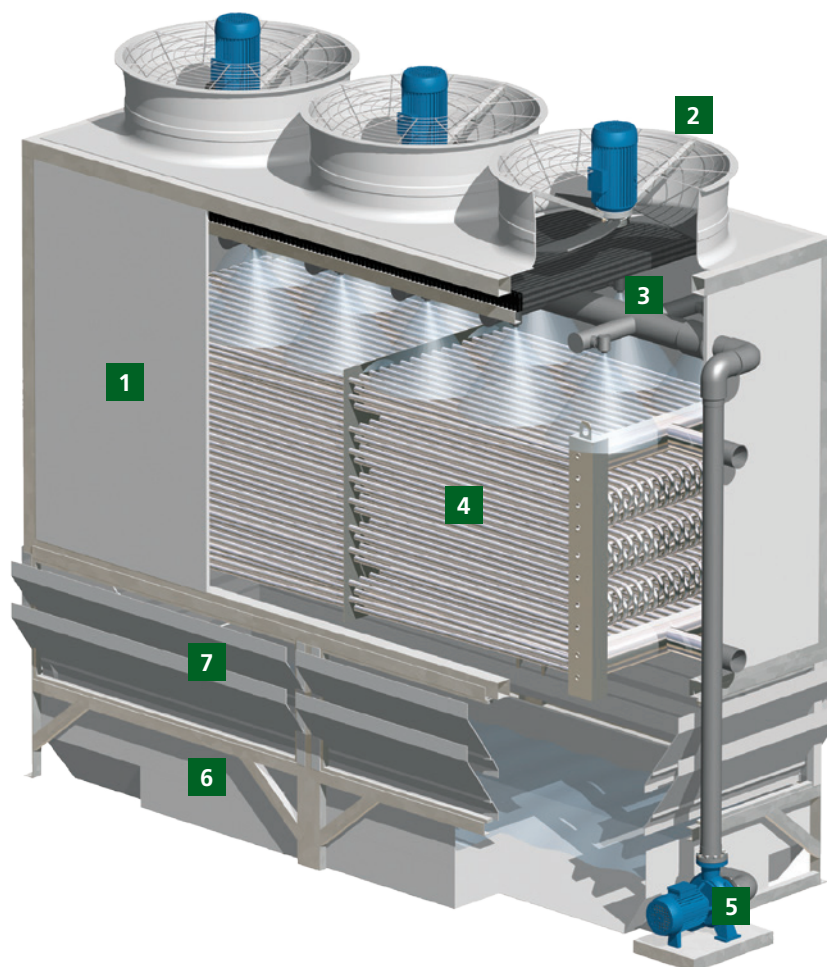

1 Structure and main casing
Construction Materials:
 steel supporting structure, hot-dip galvanised after fabrication, sandwich panelling in 22 mm thick fibreglass.
Characteristics:

- optimum mechanical resistance
- good sound-absorption properties
- non-corroding
- easy internal inspection (with optional totally removable side walls).

2 Multi-blade axial fan
Construction Materials:
 hot-dip galvanised steel (support), plastic (fan blades), stainless steel (protective grid).
Characteristics:

- high performance, low absorbed electric power, fan directly driven by the motor
- electrical wiring connection to fan motor/s with IP65 isolating switch (lockable)
- safety function of the protective grid unaltered over time
- easy replacement

3 Water distribution system
Construction Materials:
 normalised PN 10 PVC pipes, polypropylene tangential nozzles.
Characteristics:

- non-corroding
- uniform and complete spraying of the coil, full-cone spray
- exclusive MITA-design nozzles: the water flow is induced in the diffuser cone solely by the tangential connection to the main body of the nozzle, hence there are no internal parts which could cause obstructions.

4 Heat exchange coil (in compliance with PED directive 97/23/EC for the MCE Series)
Construction Materials:
 hot-dip galvanised steel (stainless steel, on request for MCC Series).
Characteristics:

- large heat exchange surface
- easy maintenance (thanks to the optional totally removable side walls).

5 Centrifugal water recirculating pump and piping of the spray water circuit

6 Basin with sloping bottom and top of the tower
Construction Materials:
 glass-mat reinforced orthophthalic polyester resin in several layers.
Characteristics:

- external surface protection by means of a gelcoat resistant to UV-radiation, to cold and hot water, to abrasion from the elements/weather conditions and to chemicals
- internal water-proofing/impermeability obtained by means of an isophthalic, paraffin-containing, impermeable and hydrorepellent gel-coat (for the basin)
- light-weight
- non-corroding.

7 Anti-splash louvers on the air inlet openings
Construction Materials:
 PVC or fibreglass.
Characteristics:

- non-corroding
- easy dismounting even after many years in service.

Dimensions and weights

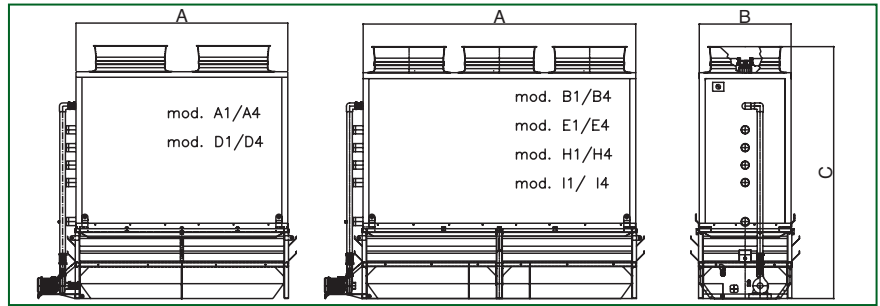

Series MCC-MCE

TYPE	WEIGHT		FAN			PUMP		ELECTRIC HEATER*		DIMENSIONS		
	Empty kg	Operation kg	N°	Power kW (cad)	Air flow m³/s (each)	Power kW	Air flow l/s	N°	Power kW (each)	A mm	B mm	C mm
A1/A4	980-1300	1980-2350	2	0,75	2,68	1,1	4,72	1	2	1870	1030	3160-3400
B1/B4	1330-1800	2785-3325	3	0,75	2,5	1,1	7,3	1	3	2770	1030	3160-3400
D1/D4	1460-2020	3225-3865	2	1,5	4,86	1,1	9,72	1	3	2850	1235	3250-3480
E1/E4	1765-2470	4065-4845	3	1,1	4,17	1,5	12,5	1	4,5	3670	1235	3250-3480
H1/H4	2130-2990	4750-5735	3	1,5	5,61	2,2	13,9	1	4,5	3670	1505	3460-3700
I1/I4	2500-3670	5790-7070	3	2,2	6,95	3	18,9	1	7,5	4570	1505	3610-3875

* optional

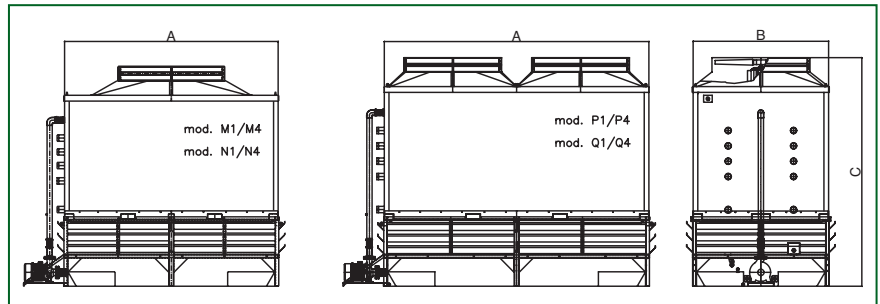

Series MCC-MCE

TYPE	WEIGHT		FAN			PUMP		ELECTRIC HEATER*		DIMENSIONS		
	Empty kg	Operation kg	N°	Power kW (cad)	Air flow m³/s (each)	Power kW	Air flow l/s	N°	Power kW (each)	A mm	B mm	C mm
M1/M4	2700-3820	6290-7570	1	5,5	20,55	3	18,9	1	7,5	2850	2340	3650-3890
N1/N4	3265-4675	7815-9375	1	7,5	26,8	3	25	1	7,5	3690	2340	3650-3890
P1/P4	4015-5715	9600-11500	2	5,5	16,67	4	30,55	2	5	4570	2340	3800-4030
Q1/Q4	4745-6965	11030-13500	2	5,5	20,14	4	36,11	2	7,5	5500	2340	3800-4030

* optional

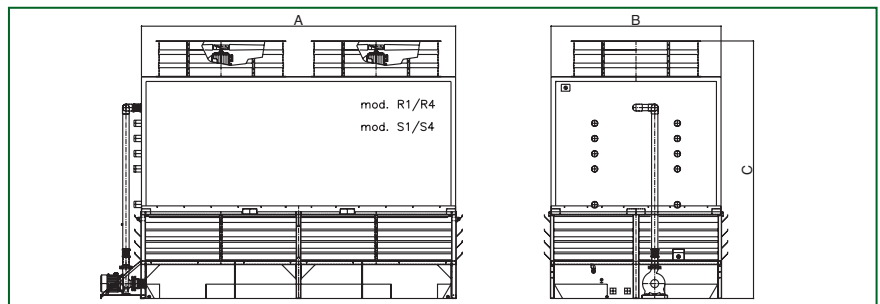

Series MCC-MCE

TYPE	WEIGHT		FAN			PUMP		ELECTRIC HEATER*		DIMENSIONS		
	Empty kg	Operation kg	N°	Power kW (cad)	Air flow m³/s (each)	Power kW	Air flow l/s	N°	Power kW (each)	A mm	B mm	C mm
R1/R4	4980-7240	11480-14040	2	5,5	20,55	4	36,11	2	7,5	4520	2960	4285-4560
S1/S4	5655-8220	13655-16580	2	5,5	24,72	5,5	44,5	2	7,5	5470	2960	4285-4560

* optional

Technical data not binding, please contacts MITA Technical Dept. for full details



Via Antonio M. Fontana, 1
Tel. +39 0382.67.599
www.mita-tech.it

I - 27010 Siziano (PV)
Fax +39 0382.617.640
e-mail: info@mita-tech.it

